

REMOTE CONTROLLER REPEATER

RC 24

The **RC-24 Remote Controller** makes it possible to operate and control in-line Maselli analyzers from a distant location. This is particularly useful when an analyzer is installed in a position which is difficult to get to, or if the analyzer in question is not equipped with a display unit.

The **RC-24** is connected to the analyzer by an RS485 serial interface and has the capability to repeat the same displays and commands found on the unit installed in-line. This allows the operator to behave as if they were acting directly on the analyzer itself.

Main functions of the RC-24:

the features of the unit include:

- RS485 serial connection to a Maselli analyzer for displaying in-line measurement data, performing calibration adjustments, setting operating parameters and monitoring analyzer diagnostics.
- RS485 serial connection to a PC with a dedicated software package for the acquisition, processing and display of in-line measurement data.
- Auxiliary RS485 serial connection which can be configured for PROFIBUS DP or ETHERNET/IP communication using optional interface modules.
- Capability of directly measuring and displaying data from an in-line pH probe
- The ability to measure and display external process variables such as temperature, via programmable analogue input channels.
- Provision of two programmable analogue output channels (0...20mA or 4...20mA)
- Two programmable alarm output contacts
- Two programmable digital inputs.

The **RC-24** can be installed in two different ways:

- **Panel** mounting
- **Wall** mounting



INTERFACES

DIGITAL

- No. 1 RS485 for connection to a Maselli analyzer.
- No. 1 RS485 for connection to a Maselli Multilab remote control "CM00" and data acquisition system, or a remote PC running "Labtech" or similar acquisition software.
- No. 1 customizable RS485 connection for optional PROFIBUS or ETHERNET/IP communication.

ANALOG

Inputs:

- No. 1 configurable channel for temperature data acquisition (Pt1000).
- No. 1 configurable channel for pH data acquisition.
- No. 2 configurable channels for the acquisition of other mV or mA process variables or for powering a two-wire transmitter.

Outputs:

- No. 2 0...20mA or 4...20mA output channels (470Ω max.) with programmable scaling.

CONTACTS

Inputs:

- No. 2 configurable volt free inputs.

Outputs:

- No. 2 volt free relay alarm outputs (1A/24V DC/AC).

POWER SUPPLIES

- AC 24V ±10% 50/60Hz 10VA
- DC 24V ±10% 10W

Ambient temperature limits:

-10 to +45 °C (14 to 13 °F)

Protection rating

IP65 in accordance with EN60529

Electronic section:

- Central microprocessor unit with operating software on flash memory, updatable via PC.
- Colour LCD 320x240 touch screen for displaying process measurements, software menus, error messages, diagnostic values and operating status icons.
- Storage and recall of multiple 'recipes', each containing specific product and analyzer operating parameters.
- Selectable interface language for menu and message display (Italian, English, Spanish, French, German, Chinese).

Dimensions and weight:

200 (w) x 120 (h) x 90 (d), 1.2 kg.

Panel mounting

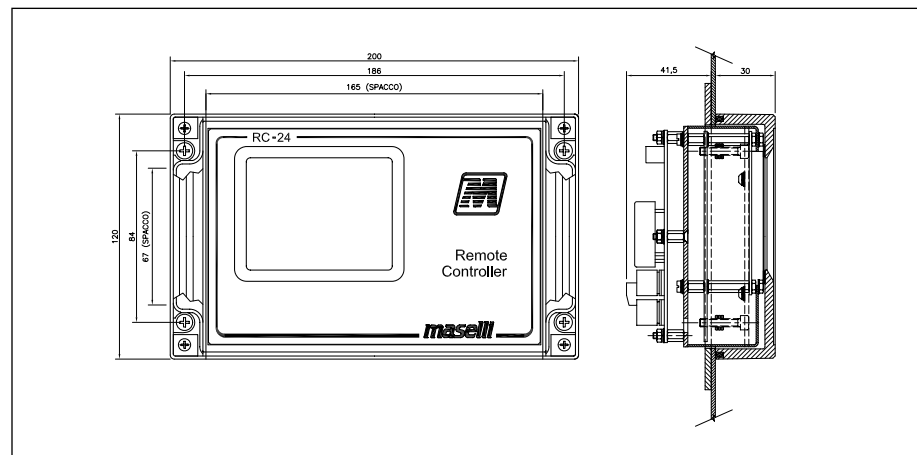

Wall mounting

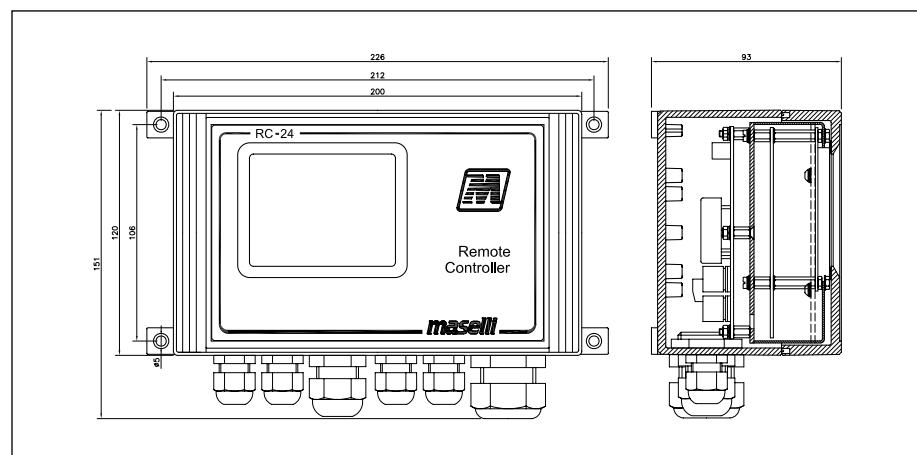

MASELLI MISURE s.p.a.

43125 Parma - Italy
Via Baganza 4/3
Tel. +39.0521.257411
Fax +39.0521.250484
info@masellimisure.com
www.masellimisure.com